

S C H Ü S S L E R
TITANIUM

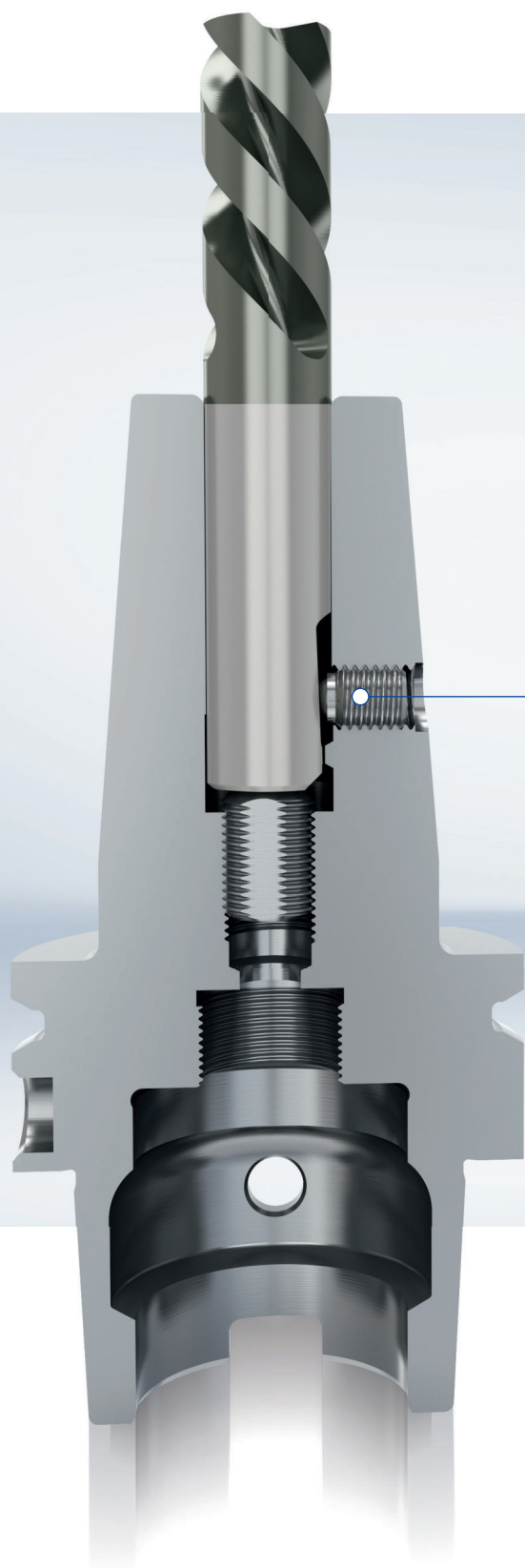

High-Performance shrink
fit chuck with anti-
pull-out function

SCHÜSSLER TITANUM

1

Easy and quick handling:

Insert the tool and align at fixed link

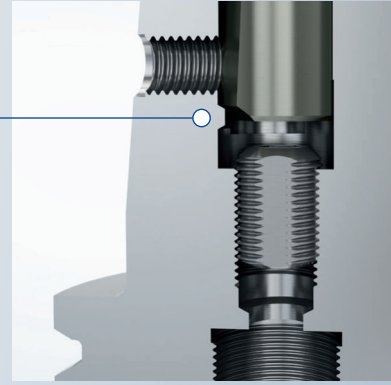

2

Flexible ballhead-screw attaches on flat surface:

Wedge effect in pull-out direction

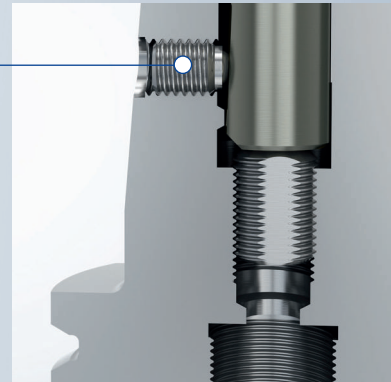

3

100 % torsion security without slippage:

due to patented laterally displaced thread

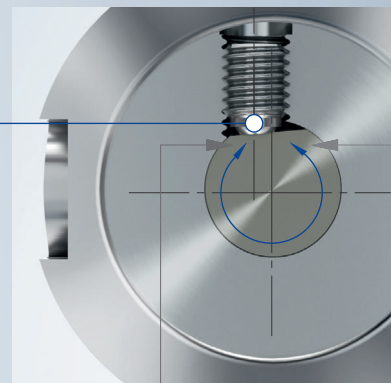

turning direction
when slipping

cutting
direction

The Schüssler shrink fit holder „TITANIUM“

with anti-pull-out function and twist security has been especially developed for HPC machining of high-strength and heavy machinable materials (such as titanium and aluminum alloys). These materials are often used for components in aerospace technology, energy industry, and as well as in medical technology.

With a run-out accuracy of $\leq 3\mu$, TITANIUM meets the highest quality requirements and guarantees 100% process secured machining.

The patented tool holder prevents from pulling-out as well as twisting the tool during milling and protects against high risk and costs by rejects of expensive and complex workpieces.



MADE IN GERMANY

Shrink fit holder TITANIUM with pull-out protection, HSK-A 63

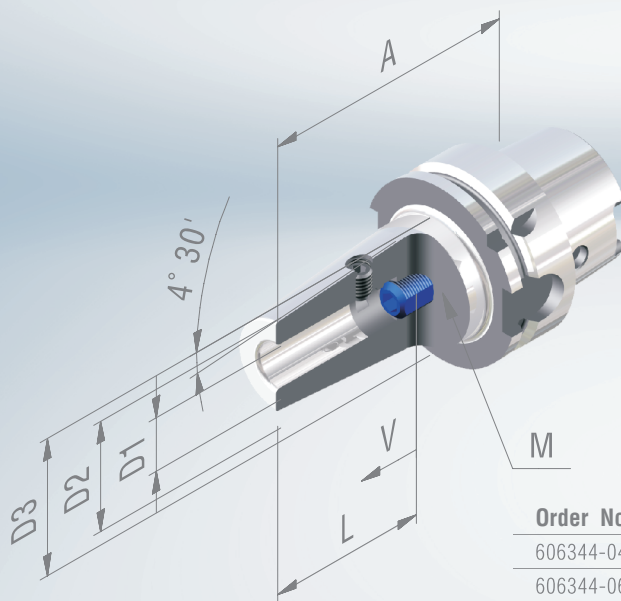

FINE BALANCED

G 2,5 at 25.000^{min-1}
or max. residual imbalance
 ≤ 1 gmm

Order No.	HSK	D1	A	D2	D3	V	L	M	Group
606344-04	63	12	90	33	42	6	48	M10x1	D
606344-06	63	16	95	33	42	6	51	M12x1	D
606344-08	63	20	100	44	53	6	53	M16x1	D

Shrink fit holder TITANIUM with pull-out protection, HSK-A 100

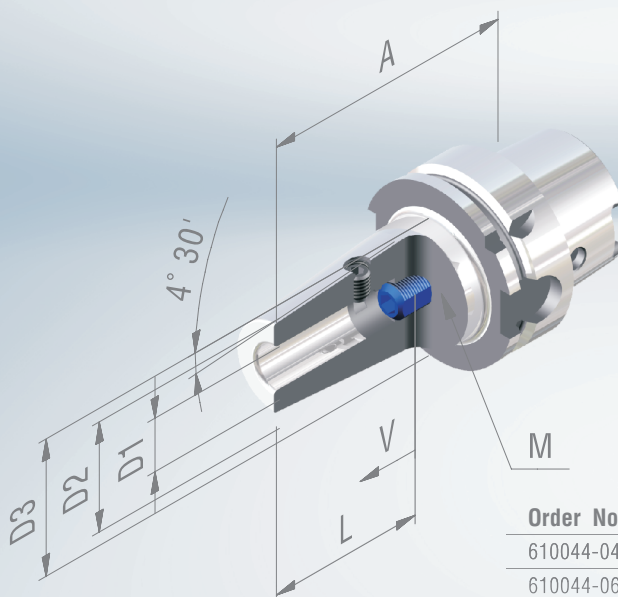

FINE BALANCED

G 2,5 at 25.000^{min-1}
or max. residual imbalance
 ≤ 1 gmm

Order No.	HSK	D1	A	D2	D3	V	L	M	Group
610044-04	100	12	95	33	42	6	48	M10x1	D
610044-06	100	16	100	33	42	6	51	M12x1	D
610044-08	100	20	105	44	53	6	53	M16x1	D

Shrink fit holder TITANIUM with pull-out protection, SK 40 Form AD/B

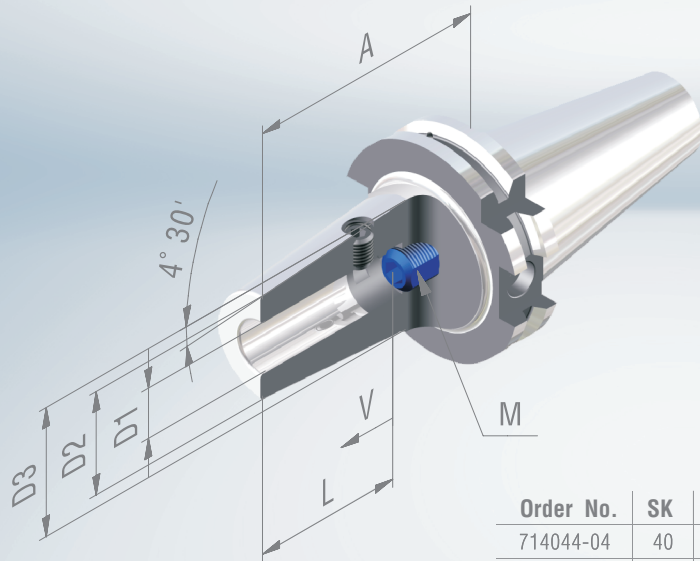

FINE BALANCED
 G 2,5 at 25.000^{min-1}
 or max. residual imbalance
 ≤ 1 gmm

Order No.	SK	D1	A	D2	D3	V	L	M	Group
714044-04	40	12	80	33	42	6	48	M10x1	D
714044-06	40	16	80	33	42	6	51	M12x1	D
714044-08	40	20	80	44	50	6	53	M16x1	D

Shrink fit holder TITANIUM with pull-out protection, SK 50 Form AD/B

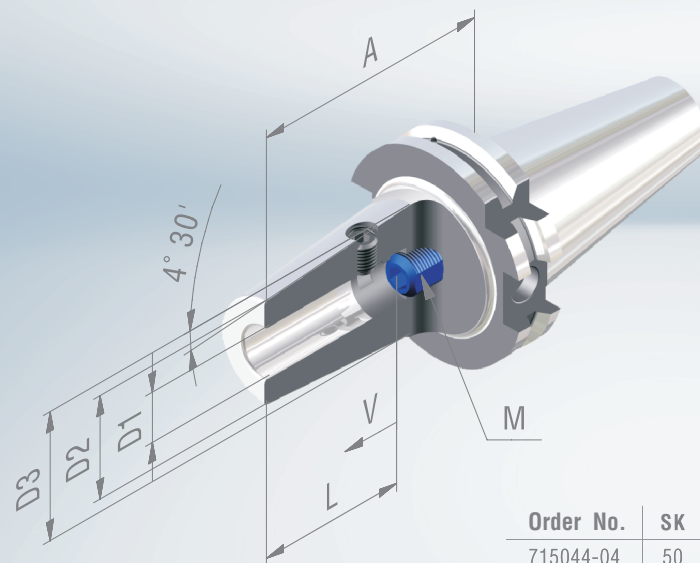

FINE BALANCED
 G 2,5 at 25.000^{min-1}
 or max. residual imbalance
 ≤ 1 gmm

Order No.	SK	D1	A	D2	D3	V	L	M	Group
715044-04	50	12	80	33	42	6	48	M10x1	D
715044-06	50	16	80	33	42	6	51	M12x1	D
715044-08	50	20	80	44	53	6	53	M16x1	D

Karl Schüssler GmbH & Co.KG
 Bahnhofstraße 108
 D-72411 Bodelshausen
 Phone: +49 7471 / 95 90-0
 info@k-schuessler.de

sk
 the μ -maker
SCHÜSSLER